

D

D

C

C

B

B

A

A

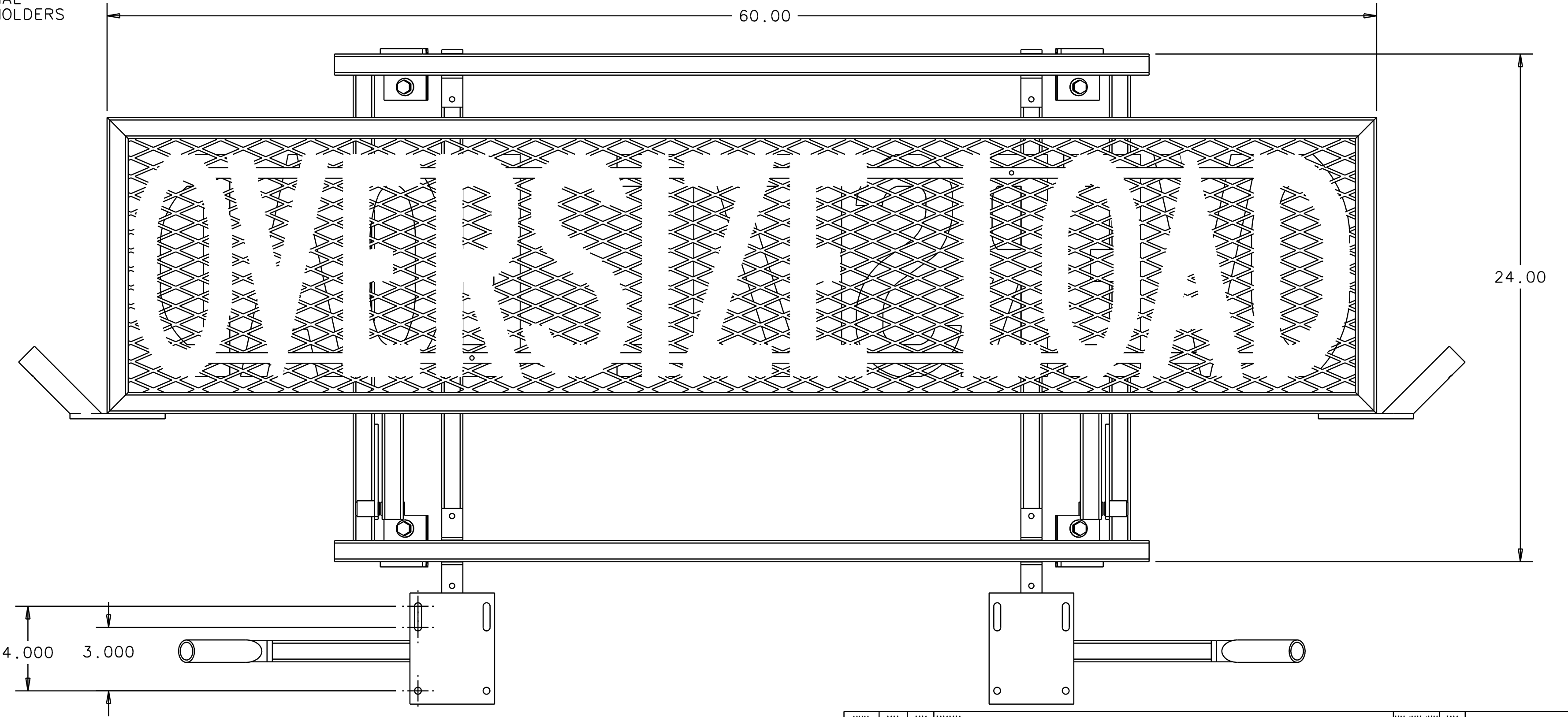
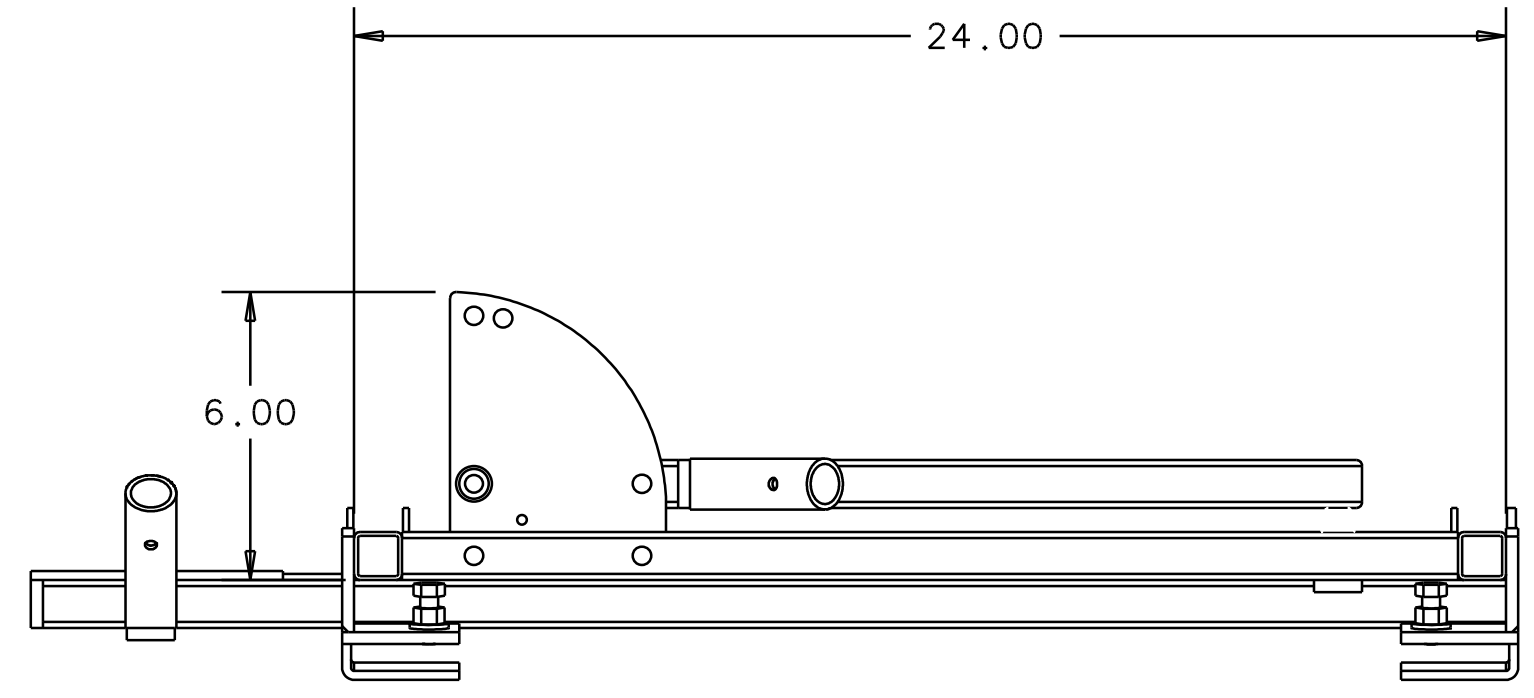
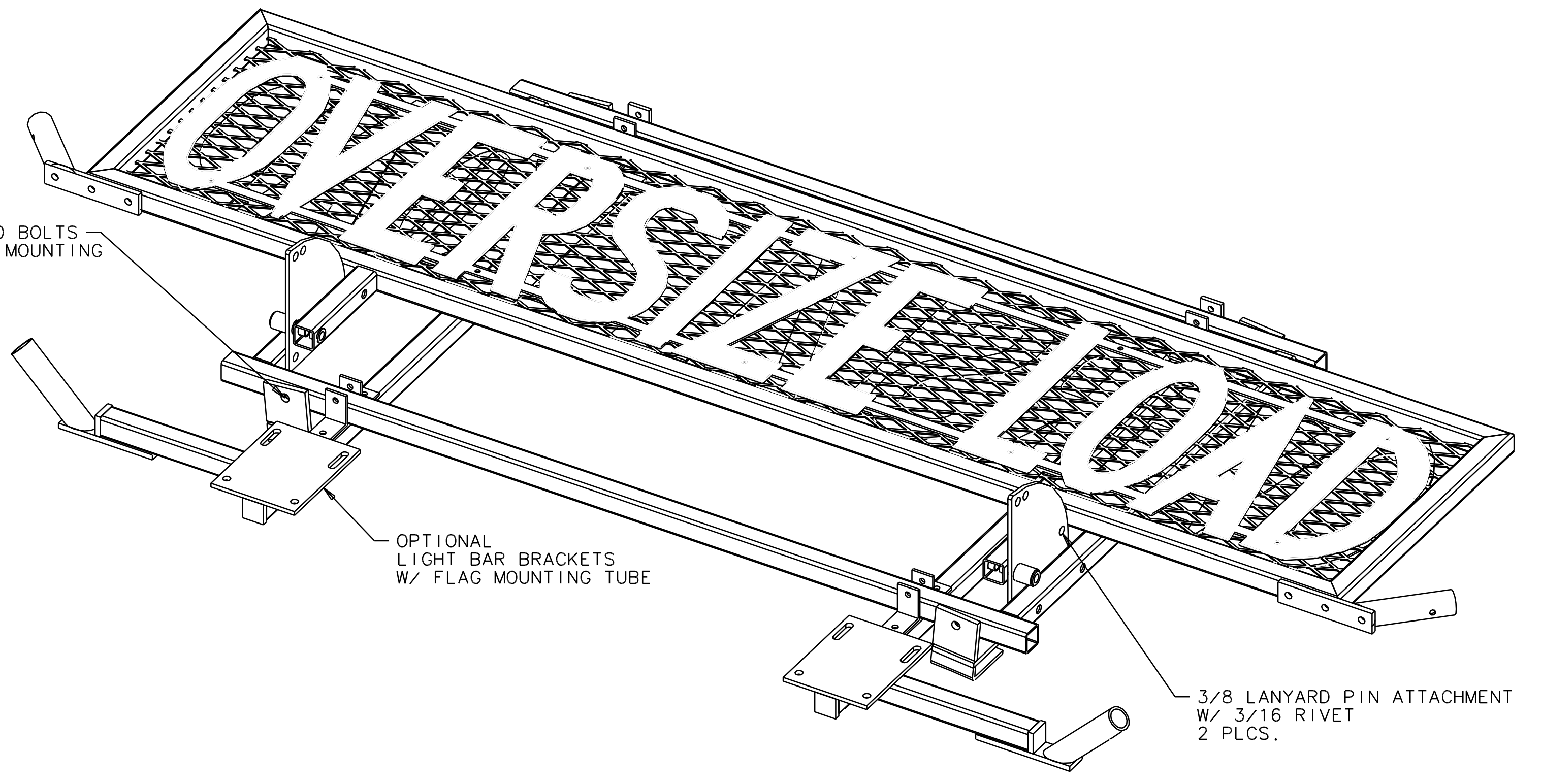
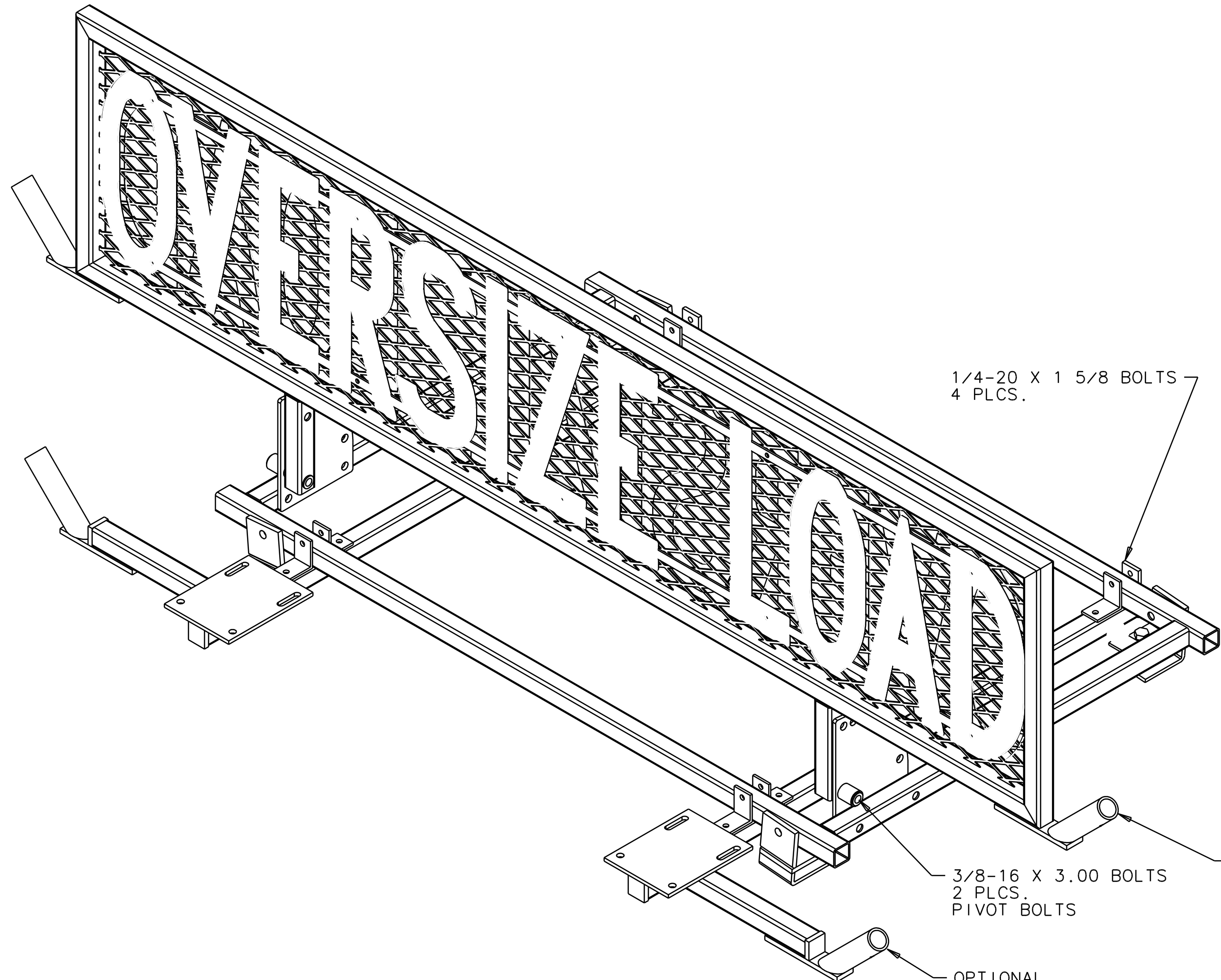

NOTE:
USE GREASE ON ALL STAINLESS STEEL HARDWARE

ECN	ZONE	REV	DESCRIPTION	DATE	BY
XXX	XX	XX	XXXX	XX/XX/XX	XX
<p>TOLERANCES: FRACTIONS ±1/16 DECIMALS ±.1 ANGLES ±.01 XXX ±.005</p> <p>ALL DIMENSIONS IN INCHES UNLESS OTHERWISE SPECIFIED DO NOT SCALE DRAWING</p> <p>3RD ANGLE PROJECTION</p> <p>ALL WELDING SHALL CONFORM TO: ANSI/AWS D1.1-99 AND ANSI/AWS D1.2-97, OR ANSI/AWS-D14.3-94</p> <p>MODEL (FIRST USED) 1183000007</p> <p>MAT'L SPEC. NUMBER</p> <p>APPROVALS</p> <p>DATE</p> <p>11/25/05</p> <p>11/25/05</p>					
<p>THIS DRAWING IS PROPERTY OF BLAZING TECHNOLOGIES AND IS NOT TO BE REPRODUCED OR USED DIRECTLY OR INDIRECTLY IN ANY WAY DETRIMENTAL TO THE INTEREST OF BLAZING TECHNOLOGIES.</p>					
<p>BLAZING TECHNOLOGIES INCORPORATED</p>			<p>TITLE O.L. SIGN ASSEMBLY LUGGAGE RACK CROSS BAR</p>		
<p>SIZE DWG NO D 1-183-000007</p>			<p>REV #</p>		
<p>ECC 00519</p>			<p>SCALE 1:4 SHEET 01 OF 01</p>		